

ASTRONOMY AND ASTROPHYSICS-I: Assignment 1

Department of Physics
Savitribai Phule Pune University
July – December 2019

26 August 2019

To be returned in the class on 4 September 2019

-
- The deadline for the submission of the solutions of this assignment will be strictly enforced. No marks will be given if the assignment is not returned in time.
 - You are free to discuss the solutions with friends, seniors and consult any books.
 - Let me know if you find anything to be unclear or if you think that something is wrong in any of the questions.
-

1. Magnitude system:

- (a) If the absolute magnitude of the Sun is 4.755, show that the luminosity of a star is related to its absolute magnitude by

$$M = 4.755 - 2.5 \log_{10} \left(\frac{L}{L_{\odot}} \right).$$

- (b) If the absolute magnitude of a star is found to be 0.6, find its luminosity in units of erg s^{-1} .
(c) Consider another star whose parallax is measured to be $0.01''$. Its apparent magnitude is 6.0. Find the absolute magnitude and luminosity (in units of erg s^{-1}) of the star.

[2 + 2 + 4]

2. Isothermal sphere: Consider a spherically symmetric galaxy having a radial density profile

$$\rho(r) = \rho_0 \left(\frac{r}{r_0} \right)^{-2}.$$

- (a) Find the mass $M(< r)$ contained within radius r .
(b) Compute the gravitational potential $\Phi(r)$ within the galaxy.
(c) Compute the rotational velocity $v_c(r)$ of the galaxy.

[3 + 2 + 2]

3. Jeans theorem: Suppose $K(\vec{x}, \vec{v})$ is a constant of motion as a star moves around within a stellar system (it can be, e.g., energy or angular momentum or any other conserved quantity). Show that a phase space distribution function of the form $f(K(\vec{x}, \vec{v}))$ will give a solution of the collisionless Boltzmann equation.

[5]

4. Time periods for the isochrone potential: Show that, for the isochrone potential

$$\Phi(r) = -\frac{GM}{b + \sqrt{r^2 + b^2}},$$

the radial time period is given by

$$T_r = \frac{2\pi GM}{(-2E)^{3/2}},$$

while the change in azimuthal angle during this period is given by

$$\Delta\psi = \pi \left(1 + \frac{L}{\sqrt{L^2 + 4GMb}} \right).$$

What happens to $\Delta\psi$ when $b \rightarrow 0$ and $b \rightarrow \infty$?

[10]

5. **Optional problem: Dynamical friction:** We consider the motion of a body of mass M through a population of stars of individual mass m . We first study the effect on M of an encounter with a single star, and then add the effects of successive encounters with different stars. A single encounter can be described by the motion of the reduced mass in the centre of mass frame.

(i) Let (\vec{x}_M, \vec{v}_M) and (\vec{x}_m, \vec{v}_m) be the positions and velocities of M and m , respectively; let $\vec{x} = \vec{x}_m - \vec{x}_M$ and $\vec{v} = \dot{\vec{x}}$. Then, show that the trajectory of the reduced mass μ is given by

$$\frac{1}{r} = C \cos(\psi - \psi_0) + \frac{G(m+M)}{L^2}, \quad C = \sqrt{\frac{2E}{\mu L^2} + \frac{G^2(m+M)^2}{L^4}},$$

where $\vec{x} = (r, \psi)$ in polar coordinates in the plane of motion, E is the energy and L is the magnitude of the angular momentum.

(ii) Let the component of the initial separation vector that is perpendicular to the initial velocity vector $\vec{v}_{-\infty} = \vec{v}(t = -\infty)$ have length b (see the figure). We call b the **impact parameter** of the encounter. What are the values of L and E at the initial time $t \rightarrow -\infty$?

Hence show that

$$C = \frac{1}{b} \sqrt{1 + \frac{G^2(m+M)^2}{b^2 v_{-\infty}^4}}.$$

What is the magnitude of the velocity at $t \rightarrow \infty$?

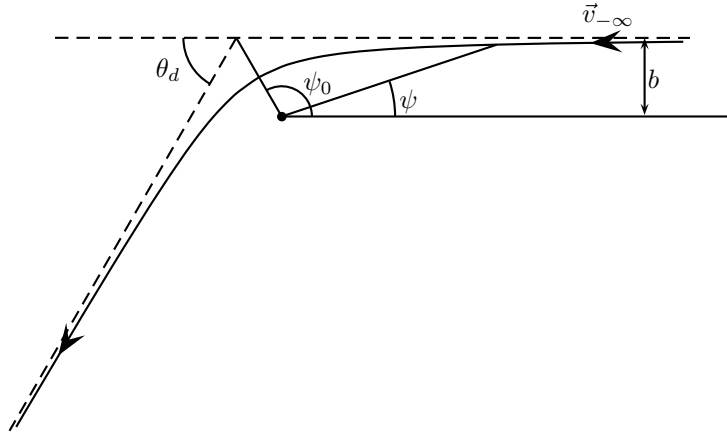

(iii) For what value of ψ does the trajectory reaches the point of closest approach to the centre of mass?

(iv) Show that

$$\begin{aligned} \cos \psi_0 &= -\frac{G(m+M)}{\sqrt{b^2 v_{-\infty}^4 + G^2(m+M)^2}}, \\ \sin \psi_0 &= \frac{b v_{-\infty}^2}{\sqrt{b^2 v_{-\infty}^4 + G^2(m+M)^2}}, \\ \tan \psi_0 &= -\frac{b v_{-\infty}^2}{G(m+M)}. \end{aligned}$$

(v) If $\Delta \vec{v}_m$ and $\Delta \vec{v}_M$ are the changes in the velocities of m and M during the encounter, show that

$$\Delta \vec{v}_m = \frac{M}{m+M} \Delta \vec{v}, \quad \Delta \vec{v}_M = -\frac{m}{m+M} \Delta \vec{v}.$$

(vi) Show that the angle of deflection θ_d (see the figure) is related to ψ_0 by

$$\theta_d = 2\psi_0 - \pi.$$

(vii) Let $\Delta v_{M\parallel}$ and $\Delta v_{M\perp}$ be the change in the velocity of M in the direction parallel and perpendicular to $\vec{v}_{-\infty}$, respectively. Show that

$$\begin{aligned}\Delta v_{M\parallel} &= -\frac{m}{m+M}\Delta v_{\parallel} = -2v_{-\infty}\frac{G^2m(m+M)}{b^2v_{-\infty}^4 + G^2(m+M)^2}, \\ \Delta v_{M\perp} &= -\frac{m}{m+M}\Delta v_{\perp} = 2v_{-\infty}^3\frac{Gmb}{b^2v_{-\infty}^4 + G^2(m+M)^2}.\end{aligned}$$

(viii) Show that for $b \gg G(m+M)/v_{-\infty}^2$, if we keep terms upto $\mathcal{O}(b^{-1})$, we get

$$\Delta v_{\parallel} \rightarrow 0, \quad \Delta v_{\perp} \approx \frac{2Gm}{bv_{-\infty}}.$$

(ix) If the star of mass M travels through an infinite homogeneous sea of stars, argue that the changes $\Delta\vec{v}_{M\perp}$ would sum to zero, while the changes $\Delta\vec{v}_{M\parallel}$ would form a non-zero resultant. In consequence, the mass M suffers a steady deceleration, which is said to be due to **dynamical friction**.